

# TB85J



# Straight Jib Boom

# Snorkel



Sales  
Rental  
Service



**HELI**.be

Vantegemstraat 9 | B-9230 Wetteren | +32 9 368 80 80 | info@heli.be

## Snorkel TB85J

Platform	Machine Dimensions	Performance
Height.....84'11" (25.9 m)	Stowed Length.....42'2" (12.85 m)	Power Source.....Gas or Diesel
Size.....30" x 96" (76 cm x 244 cm)	Stowed Height .....9'8" (2.95 m)	Fuel Capacity.....40 gal (151 L)
Capacity.....500 lbs (227 kg)	Wheelbase .....12' (3.66 m)	Hydraulic Capacity.....65 gal (246 L)
Construction.....Aluminum	Width.....8'6" (2.6 m)	Drive Speed
	Ground Clearance .....13" (33 cm)	Elevated.....1 mph (1.6 km/h)
	Weight.....30,700 lbs (13,925 kg)	Stowed.....3 mph (4.8 km/h)
	Tire Size.....15" x 22 1/2" (38 cm x 57 cm)	Gradeability (Theoretical).....61%
		Horizontal Reach.....76'8" (23.4 m)

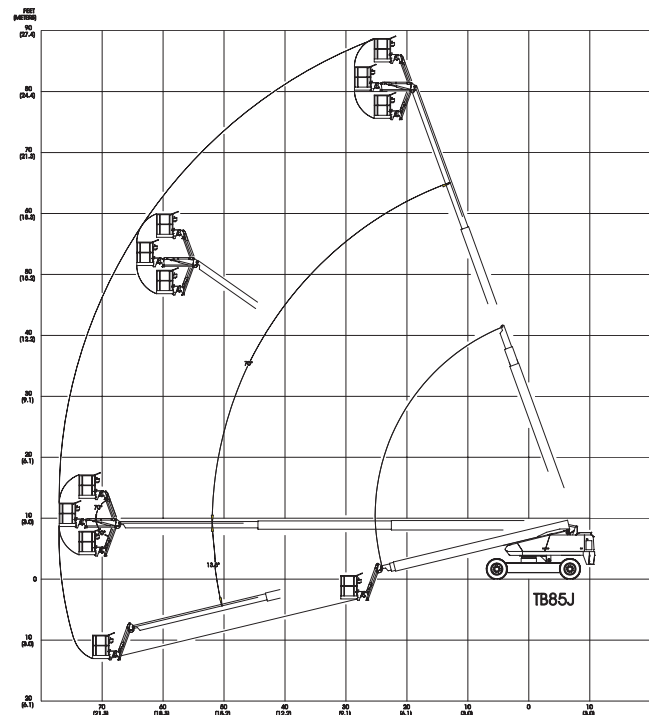
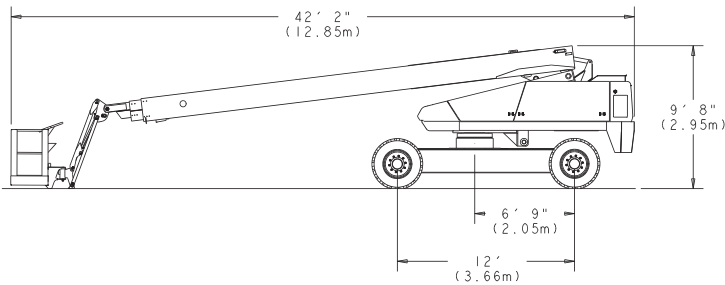

Sales  
Rental  
Service



**HELI.be**

Vantegemstraat 9 | B-9230 Wetteren | +32 9 368 80 80 | info@heli.be

### Standard Features

- 360 degree continuous turntable rotation
- Prop. drive, lift, swing & extend
- Engine anti-restart
- Tie down lugs
- 170 degree hydraulic Platform rotation
- 12 volt emergency operated power
- Manual bleed down valve
- Hydraulic oil level/temp gauges
- Foam filled tires
- Driveable at full height
- Tilt alarm
- 125 volt GFCI AC outlet
- Aluminum upper booms
- Hour meter
- High engine temp/low oil pressure shut down
- Lifting lugs
- Extendable rear axles
- Operator Horn
- Four wheel drive

### Options

- Platform control box cover
- Flashing light on boom
- Swinging gate
- Sandblast protection kit
- Driving lights
- Dual Fuel
- Platform work lights
- Spark arrestor muffler
- Cold weather start kit
- Hydraulic Sys. Cold weather Warm-up Kit
- Two wheel drive option deduct
- Drive motion alarm
- Tow kit
- Airline to Platform
- AC Generator
- Platform – 60" x 30" (152 x 76 cm) Aluminum 600 lb Cap. (272 kg)
- Platform – 60" x 30" (152 x 76 cm) Steel 500 lb Cap. (227 kg)

DANGER: Models described in this brochure are NON-INSULATED and do not provide electrocution protection from contact with or close proximity to energized conductors which is pointed out on decals and placards attached to the machine. Only qualified and trained operators are to be authorized to use and operate a work platform. Aerial work platforms must be elevated only on firm, level surface. Products in this brochure comply with applicable ANSI Standards. This literature is for illustrative purposes only. Consult Operating Maintenance and Parts Manuals for proper procedures. Specifications may vary and are subject to change without notice or obligation.

**Manufacturing Plant**  
2009 Roseport Road  
Elwood, Kansas 66024  
800-255-0317  
785-989-3000

**Australia**  
26 Redfern Road  
Wetheril Park NSW  
2164 Australia  
(02) 9725 4000