

### Specifications

Models	Z-30/20N		Z-30/20N RJ	
Measurements	Metric	US	Metric	US
Working height maximum*	11.14 m	36 ft	10.89 m	35 ft 2 in
Platform height maximum	9.14 m	30 ft	8.89 m	29 ft 2 in
Horizontal reach maximum	6.53 m	21 ft 5 in	6.25 m	20 ft 6 in
Up and over clearance maximum	3.86 m	12 ft 8 in	3.86 m	12 ft 8 in
▲ Platform length	0.76 m	2 ft 6 in	0.76 m	2 ft 6 in
▲ Platform width	1.17 m	3 ft 10 in	1.17 m	3 ft 10 in
▲ Height - stowed	2 m	6 ft 6.5 in	2 m	6 ft 6.5 in
▲ Length - stowed	5.11 m	16 ft 9 in	5.31 m	17 ft 5 in
▲ Storage height	2.08 m	6 ft 10 in	2.24 m	7 ft 4 in
▲ Storage length	3.5 m	11 ft 6 in	3.66 m	12 ft
▲ Width	1.19 m	3 ft 11 in	1.19 m	3 ft 11 in
▲ Wheelbase	1.58 m	5 ft 2 in	1.58 m	5 ft 2 in
▲ Ground clearance - center	0.09 m	3.5 in	0.09 m	3.5 in

### Productivity

Lift capacity	227 kg	500 lbs	227 kg	500 lbs
Platform rotation	180°	180°	180°	180°
Vertical jib rotation	139°	139°	139°	139°
Horizontal jib rotation	—	—	180°	180°
Turntable rotation	355° non-continuous		355° non-continuous	
Turntable tailswing	zero	zero	zero	zero
Drive speed - stowed	4.8 km/h	3.0 mph	4.8 km/h	3.0 mph
Drive speed - raised**	1.1 km/h	0.68 mph	1.1 km/h	0.68 mph
Gradeability - stowed***	35%	35%	35%	35%
Turning radius - inside	1.65 m	5 ft 5 in	1.65 m	5 ft 5 in
Turning radius - outside	3.23 m	10 ft 7 in	3.23 m	10 ft 7 in
Controls	24 V DC proportional		24 V DC proportional	
Tyres - solid non-marking	56 x 18 x 45 cm	22x7x17.75 in	56 x 18 x 45 cm	22x7x17.75 in

### Power

Power source	48 V DC (eight 6 V batteries 350 Ah capacity)		48 V DC (eight 6 V batteries 350 Ah capacity)	
Auxiliary power unit	24 V DC	24 V DC	24 V DC	24 V DC
Hydraulic tank capacity	15.1 L	4 gal	15.1 L	4 gal

### Sound & Vibration Levels

Sound pressure level (ground)	<70 dBA	<70 dBA	<70 dBA	<70 dBA
Sound pressure level (platform)	<70 dBA	<70 dBA	<70 dBA	<70 dBA
Vibration	<2.5 m/s <sup>2</sup>	<8 ft 2 in/s <sup>2</sup>	<2.5 m/s <sup>2</sup>	<8 ft 2 in/s <sup>2</sup>

### Weight\*\*\*\*

	6,428 kg	14,170 lbs	6,450 kg	14,220 lbs
--	----------	------------	----------	------------

### Standards Compliance

EU Directives: 2006/42/EC - Machinery (harmonized standard EN280:2013); 2004/108/EC (EMC); 2006/95/EC (LVD)

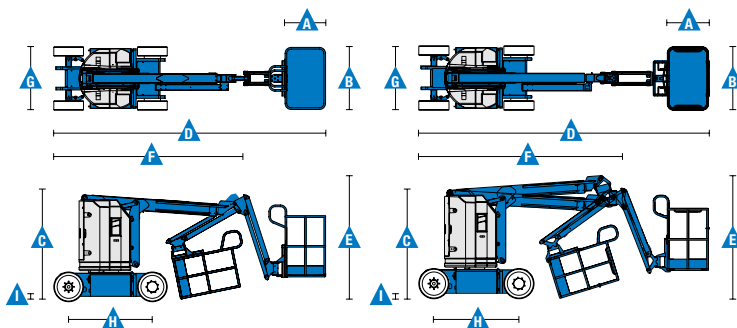

### Range Of Motion Z-30/20N

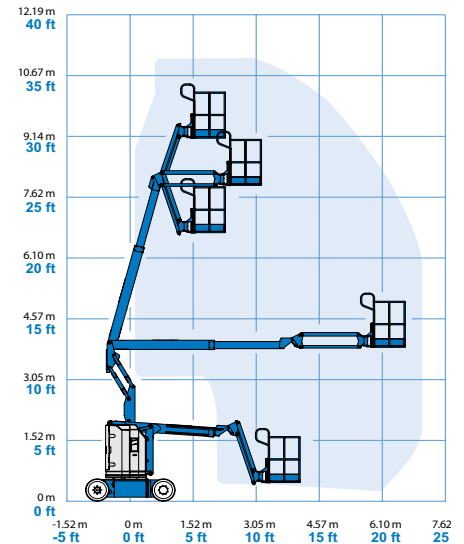

### Range Of Motion Z-30/20N RJ

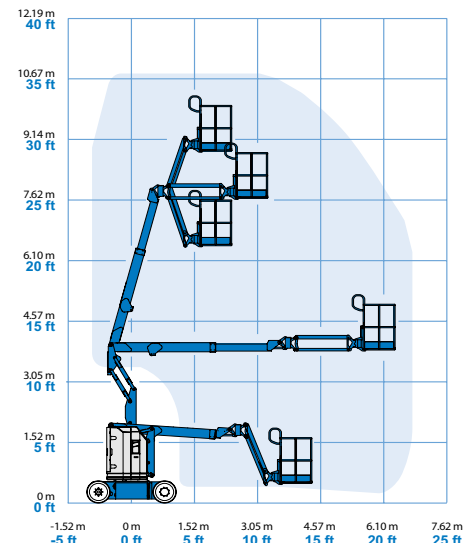

### Jib Range of Motion Z-30/20N RJ

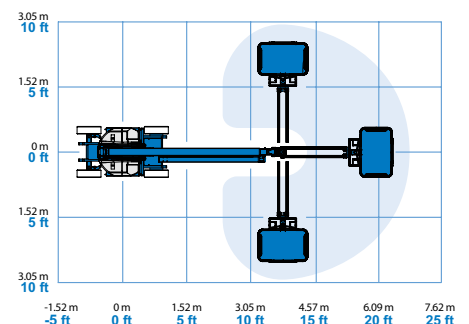

\* The metric equivalent of working height adds 2 m to platform height. U.S. adds 6 ft to platform height.

\*\* In lift mode (platform raised), the machine is designed to operate on firm, level surfaces only.

\*\*\* Gradeability applies to driving on slopes. See operator's manual for details regarding slope ratings.

\*\*\*\* Weight will vary depending on options and/or country standards.

### Features

#### Standard Features

##### Measurements

###### Z-30/20N

- 11.14 m (36 ft) working height
- 6.53 m (21 ft 5 in) horizontal reach
- 3.86 m (12 ft 8 in) up and over clearance
- Up to 227 kg (500 lbs) lift capacity

###### Z-30/20N RJ

- 10.89 m (35 ft 2 in) working height
- 6.25 m (20 ft 6 in) horizontal reach
- 3.86 m (12 ft 8 in) up and over clearance
- Up to 227 kg (500 lbs) lift capacity

##### Productivity

- 1.22 m (4 ft) jib boom with 139° working range
- Self-levelling platform
- Hydraulic platform rotation
- Proportional joystick controls
- Telematics-Ready Connector
- Thumb rocker steer
- Drive enable
- AC power cord to platform
- Horn
- Hour meter
- Tilt alarm
- Descent & travel alarms
- Flashing beacon
- 355° non-continuous turntable rotation
- Zero tailswing and front arm swing
- Certified load sensor

##### Power

- 48 V DC deep cycle battery pack
- 24 V DC auxiliary power
- Universal 30A battery smart charger
- Battery charge indicator
- Low battery voltage interrupt

#### Easily Configured To Meet Your Needs

##### Platform

- Steel 1.17 m (3 ft 10 in)

##### Jib Options

- Articulating 1.22 (4 ft) jib boom
- 1.22 m (4 ft) horizontal rotating jib boom

##### Power

- 48 V DC (eight 6V 350 Ah capacity batteries)

##### Drive

- 2 x 4

##### Tyres

- Solid rubber non-marking

#### Options & Accessories

##### Productivity

- Platform top auxiliary rail
- Air line to platform
- Power to platform (incl. plug, socket and ground fault interrupt leakage on request)
- Work lights package (2 on chassis, 2 on platform)
- Aircraft protection kit <sup>(1,2)</sup>: platform foam padding and padded disable system (except RJ model)
- Hostile environment kit <sup>(2)</sup>: cylinder bellow, boom wiper seals and platform control box covers
- Biodegradable hydraulic oil <sup>(2)</sup>
- Tilt cut-out option
- Track & Trace <sup>(3)</sup> (GPS unit providing machine location & operating information)
- Lockable platform control box cover
- Tool tray
- Operator Protective Alarm
- Keypad unlocking device

##### Power

- AGM maintenance-free batteries <sup>(2)</sup>

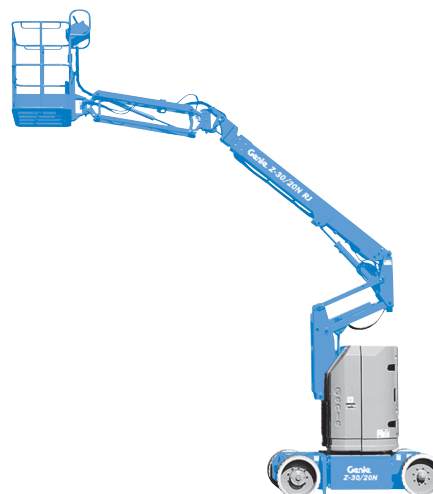

<sup>(1)</sup> Reduces platform load capacity to 199.6 kg (440 lbs)

<sup>(2)</sup> Factory-fit option only

<sup>(3)</sup> Includes a first 2 years subscription



**Sales  
Rental  
Service**

**HELI.be**

Vantegemstraat 9 | B-9230 Wetteren | +32 9 368 80 80 | info@heli.be

03/16 Part No. B109357UK

### United Kingdom

The Maltings, Wharf Road, Grantham NG31 6BH, T: +44 800 988 3739 (toll free), Fax +44 (0)1476 584334, Email AWP-InfoEurope@terex.com  
Visit [www.genielift.co.uk/locations](http://www.genielift.co.uk/locations) to view our global locations list.

### Worldwide Manufacturing And Distribution

Australia · Brazil · Caribbean · Central America · China · France · Germany · Italy · Japan · Korea · Mexico · Russia · Southeast Asia · Spain · Sweden · United Arab Emirates · United Kingdom · United States

Product specifications and prices are subject to change without notice or obligation. The photographs and/or drawings in this document are for illustrative purposes only. Refer to the appropriate Operator's Manual for instructions on the proper use of this equipment. Failure to follow the appropriate Operator's Manual when using our equipment or to otherwise act irresponsibly may result in serious injury or death. The only warranty applicable to our equipment is the standard written warranty applicable to the particular product and sale and we make no other warranty, express or implied. Products and services listed may be trademarks, service marks or trade names of Terex Corporation and/or their subsidiaries in the USA and many other countries. Genie is a registered trademark of Terex South Dakota, Inc. © 2016 Terex Corporation.

