

ATN

ZEBRA 12 V2

Articulating boom ZEBRA 12 V2

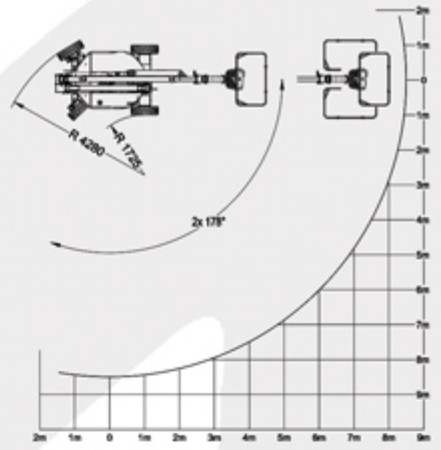

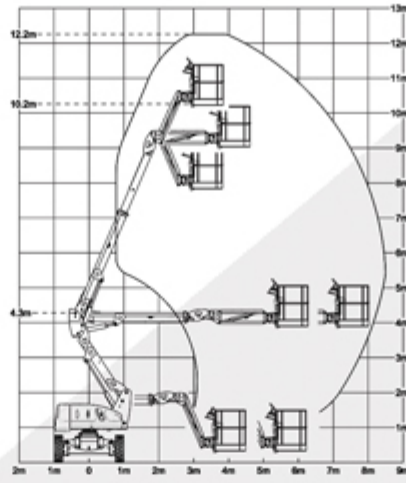
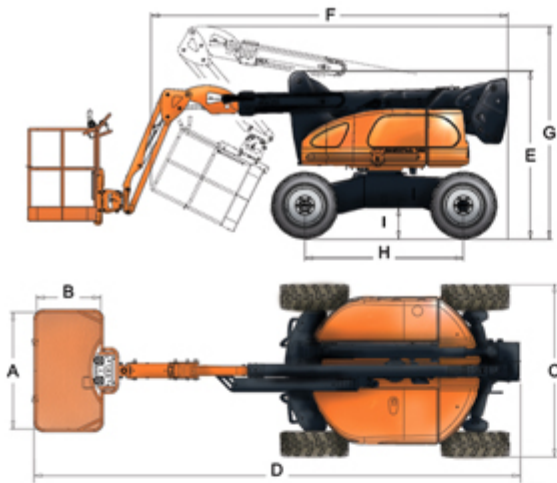

ZEBRA 12 V2

ADVANTAGES OF ZEBRA 12 V2

- Outstanding horizontal reach.
- High ground clearance.
- High drive speed.
- Proportional intuitive drive and lift controls.
- Easy to maintain (on-board diagnostic screen system).
- Designed and manufactured for heavy-duty use.

STANDARD FEATURES

- Oscillating axle.
- Permanent 4 wheel drive
- Overload sensor.
- Lifting facilities.
- On-board LCD colour diagnostic screen system.

OPTIONS

- 220V AC power to platform.
- Air line to platform.
- 2,5 KW generator
- Cold weather start kit
- Flashing light.
- Motion alarm.
- Catalysed particulate filter (F.A.P.).
- Anti crush system (A.C.S.).
- Motion stop when exceeding allowed tilt >4°
- Oil cooler
- Special paint colour(s).

CE This product complies with European regulations in force (EN 280). Due to our constant improvement policy, ATN reserves the right to make any modifications without any prior notice.

ZEBRA 12 V2	
Working height	12,20 M (40 ft. 0,3 in.)
Platform height	10,20 M (33 ft. 5 in.)
Horizontal reach	8,50 M (27 ft. 9 in.)
Up and over clearance	4,42 M (14 ft. 6 in.)
Lift capacity	230 Kg (507 lbs.)
Turntable rotation	2x178 °
Platform rotation	2x90 °
Turntable tailswing	0
Jib rotation	133 °
A Platform width	1,51 M (4 ft. 9 in.)
B Platform length	0,86 M (2 ft. 83 in.)
C Width	1,99 M (6 ft. 53 in.)
D Length- stowed	6,05 M (19 ft. 10 in.)
E Height - stowed	2,10 M (6 ft. 89 in.)
F Length - storage	4,50 M (14 ft. 9 in.)
G Height - storage	2,60 M (8 ft. 54 in.)
H Wheelbase	2,00 M (6 ft. 57 in.)
I Ground clearance centre	0,37 M (1 ft. 22 in.)
Turning radius - inside	1,73 M (5 ft. 68 in.)
Turning radius - outside	4,28 M (14 ft. 05 in.)
Tyres	31x10-20
Drive speed - stowed	6 Km/h (3,73 Mph)
Drive speed - raised	0,9 Km/h (0,56 Mph)
Gradeability - stowed	40 %
Maximum tilt value	4 °
Diesel engine	KUBOTA
Fuel tank capacity	50 L (13,2 gal.)
Hydraulic tank capacity	48 L (12,7 gal.)
Weight	5250 Kg (11,575 lbs.)
Max.ground bearing pressure	13,0 Kg/cm ² (43 psi / in. ²)
Auxiliary power unit	12 V DC



Sales
Rental
Service

HELI.be

Vantegemstraat 9 | B-9230 Wetteren | +32 9 368 80 80 | info@heli.be

ATN

Rue André Thevet,

Z.I.Guillaume Mon Amy Fauillet 47400 FRANCE

+33 (0) 553 798 320 +33 (0) 553 880 107

<http://www.atnplatforms.com>

