

# A46JE/A46JRT

## ARTICULATED BOOM LIFTS



- Class-leading articulated boom lifts
- Choose from electric or rough terrain diesel models
- Highly manoeuvrable with tight turning radius
- Superb working envelope with zero tailswing
- Robust, reliable and easy to operate

 **snorkel**  
[www.snorkellifts.com](http://www.snorkellifts.com)

# ARTICULATED BOOM LIFTS

# A46JE/A46JRT

DIMENSIONS	A46JE	A46JRT
Max. working height	16.1m	16.3m
Max. platform height	14.1m	14.3m
Max. working outreach	7.4m	7.4m
Platform size	1.0 x 1.85m	1.0 x 1.85m
Chassis width (A)	1.7m	2.1m
Overall length (B)	5.6m	5.6m
Stowed height (C)	2.0m	2.1m
Ground clearance	152mm	330mm

PERFORMANCE		
Platform capacity (SWL)	227kg	227kg
Max. drive height	14.1m	14.3m
Max. drive speed (stowed)	5.1km/h	7.2km/h
Max. drive speed (elevated)	1.3km/h	1.2km/h
Jib length	1.5m	1.5m
Jib arc	140°	140°
Platform rotation	160°	160°
Turret rotation	360° non-continuous	360° non-continuous
Raise/lower time	101/108 seconds	120/112 seconds
Gradeability	30%	45%
Inside turning radius	0.60m	0.80m
Outside turning radius	3.0m	3.1m
Tyres	Non-marking IN240/55D	High grip 355/55D625NHS 17.5
Controls	proportional	proportional
Drive system	2 wheel drive	4 wheel drive

POWER		
Power source	8 x 6V 360Ah batteries	Kubota V1505T Diesel

WEIGHT		
Gross weight	6,486kg	6,622kg

## WORKING ENVELOPE

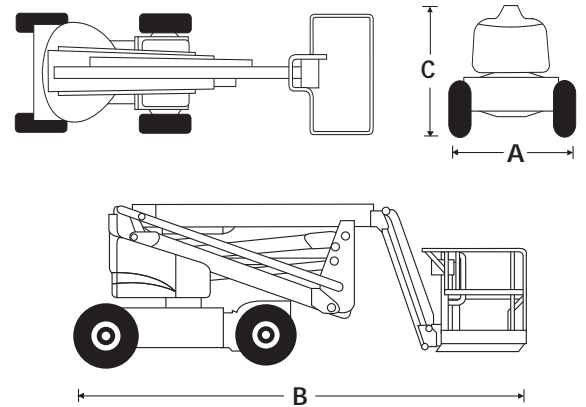
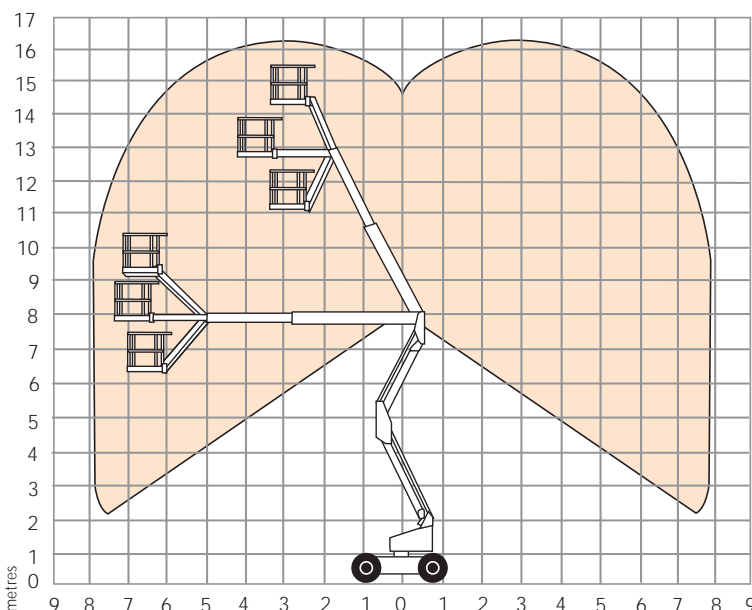

## STANDARD FEATURES

- Multi-function, variable speed platform controls
- Oscillating front axle (A46JRT)
- Proportional controls
- Power line to platform (no sockets)
- Zero tailswing
- Hour meter
- Battery charge indicator (A46JE)
- Wide rough terrain tyres, foam-filled (A46JRT)
- CE approved

## OPTIONS

- Special paint colours
- AC generator 110/200w (A46JRT)
- Amber beacon
- Drive motion alarm
- Airline to platform (A46JRT)
- Cold weather package (A46JRT)
- Light package (A46JRT)
- Extreme environment package (A46JRT)
- Aircraft package
- Deluxe aircraft package
- Diesel exhaust scrubber (A46JRT)
- Extreme cold weather package (A46JRT)



Sales  
Rental  
Service

**HELI**.be

Vantegemstraat 9 | B-9230 Wetteren | +32 9 368 80 80 | info@heli.be

**snorkel** [www.snorkellifts.com](http://www.snorkellifts.com)

Vigo Centre, Birtley Road,  
Washington, Tyne & Wear,  
NE38 9DA, U.K.

t: +44 (0) 845 1550 057

e: sales@snorkellifts.com