

MANIACCESS

150 AETJ C 150 AETJ C 3D



Self-propelled electric articulating boom lift

- Working height : 15.00 m
- Max. outreach : 7.60 m
- Up and over : 7.00 m
- Overall width : 1.50 m
- 3D option : Jib rotation



COMPACT

 **MANITOU**

150 AETJ C Compact 150 AETJ C 3D Compact

	Working height	15.00 m
	Platform height	13.00 m
	Horizontal outreach	7.60 m
	Up and over clearance	7.00 m
	Jib movement	+70° / -70°
	Jib rotation (option 3D)	+70° / -70°
	Basket rotation	140°
	Turret rotation	355°

	Platform capacity	200 kg/2 peoples
	External use	45 km/h (Maximum allowed wind speed)
	Basket size	1.20 x 0.96 m

	Width	1.50 m
	Length	6.05 m
	Stowed length (storage)	4.40 m
	Height	1.97 m
	Stowed height (storage)	2.08 m

	Turning radius inside	1.87 m
	Turning radius outside	3.96 m
	Turning radius outside (basket)	4.82 m
	Ground clearance	0.14 m
	Wheel base	2.00 m
	Drive speed	5.0 km/h
	Working speed	0.6 km/h

	Gradeability	25%
	Maximum slope accepted	5% ou 3°

	Weight	6 700 kg
--	---------------------	----------

	Tires	0.60 x 0.19 m
	Wheel steer	2 (front)
	Wheel drive	2 (back)

	Batteries	300 Ah / 2x24 V
	Battery charger	45 Ah/48 V

Standard equipment

- Protected control basket panel
- Electrical battery traction
- Negative brakes
- Lifting brackets
- Hour meter
- Warning buzzer in the basket
- 220 V predisposal
- Voltage indicator
- Safety manual pump
- Basket with mesh floor
- Bus CAN technology
- Diagnostic help integrated
- Dual electrical motors
- Rubber and no marking tires
- Integrated charger

Options

- Jib rotation (3D)

- High capacity battery (360 Ah)
- Dual voltage charger 110 V / 230 V
- Working lights
- Electric plug in the platform with circuit breaker (230 V)
- Flashing light
- Drive alarm
- All motion alarm
- Cold conditions -25°C
- Air predisposal
- Water predisposal
- Specific painting
- Biodegradable oil

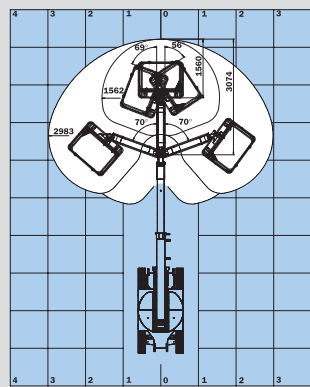
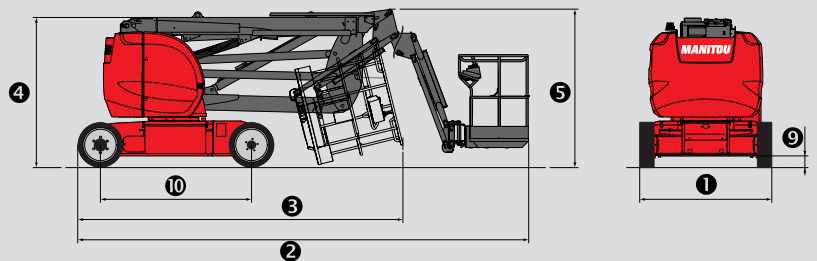
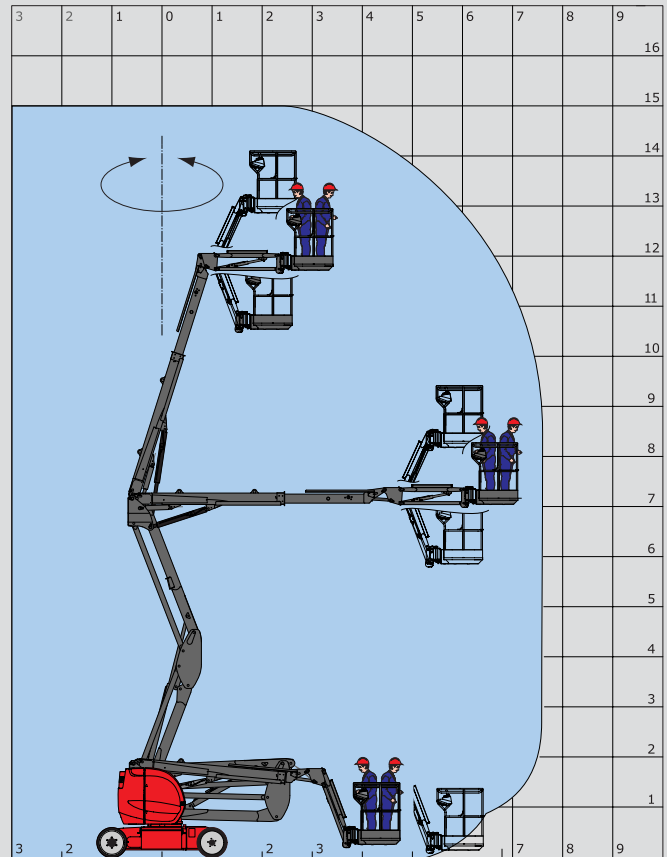

Option 3D : jib rotation

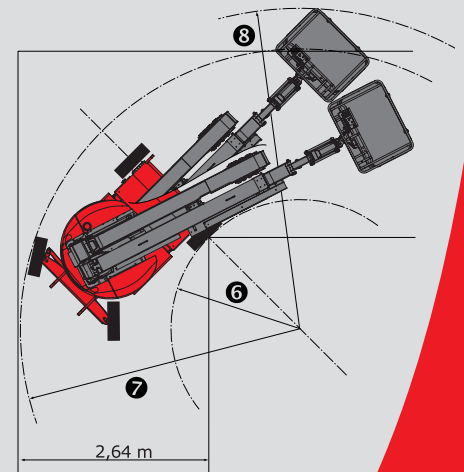

The equipment supplied with each model may differ from that described in this leaflet. For more details, contact your MANITOU dealer.



MANITOU BF SA
B.P. 249 - 44158 Ancenis Cedex - France
Tél. : 33 2 40 09 10 11 / Export Department Fax : 33 2 40 09 10 97
www.manitou.com

700344EN



**Sales
Rental
Service**



HELI.be

Vantegemstraat 9 | B-9230 Wetteren | +32 9 368 80 80 | info@heli.be

